



Total Solution Provider in Saw Device

SL12904BF

129.57MHz IF SAW Filter
4.37 MHz Bandwidth
Revision 0: 2. Oct. 2008



-
- Electrical Characteristics
 - Package Dimensions
 - Testing Environment
 - Frequency Characteristics
-

SAWNICS Inc.

460 Cheonheung-ri, Seonggeo-eup, Cheonan-si, Chungcheongnam-do, 330-836 / Korea.
Tel: +82 41 550 9372 / Fax: +82 41 550 9399 / www.sawnics.com

□ Electrical Characteristics

Maximum Ratings

Parameters Description	Unit	Minimum	Typical	Maximum
Operation Temperature Range	°C	0	45	85
Storage Temperature Range	°C	-20	-	70
Maximum DC Voltage	V	-	-	10
Maximum Input Power	dBm	-	-	28
Source Impedance (single ended) ⁽¹⁾	Ω	-	50	-
Load Impedance (single ended) ⁽¹⁾	Ω	-	50	-
Package type & size	F			
Length x Width	mm ²	-	34.7 x 12.6	-
Height	mm	-	-	5.05

Electrical Specification

Center Frequency (Fo)	MHz	129.47	129.57	129.67
Insertion Loss at Fo	dB	-	25.2	26.0
Group Delay Variation (Fo±2.07MHz)	ns	-	93	150
Phase Linearity (Fo±2.07MHz)	deg		3.4	10.0
Absolute Delay Time at Fo	us	-	3.96	4.20
Temperature Coefficient	ppm/°C	-	-0.03	-
Amplitude Ripple (Fo±2.07MHz)	dB	-	0.54	1.10
Bandwidth at -1dB	MHz	4.25	4.37	-
Bandwidth at -45dB	MHz	-	5.12	5.30
Input & Output Return Loss	dB	6	8	-
Triple transit attenuation	dBc	35	-	-
Relative Attenuation				
10MHz~122.0MHz	dBc	40	62	-
@126.93 MHz	dBc	40	65	-
@127.03 MHz	dBc	20	40	-
@132.11 MHz	dBc	20	35	-
@132.21 MHz	dBc	40	50	-
137.0MHz ~300.0MHz	dBc	40	64	-

Notes : (1) With Matching Network (Ref. Testing Environment Circuit as shown below).

Those impedances could be modified with different impedance values and/or structures, if necessary.

Package Dimensions

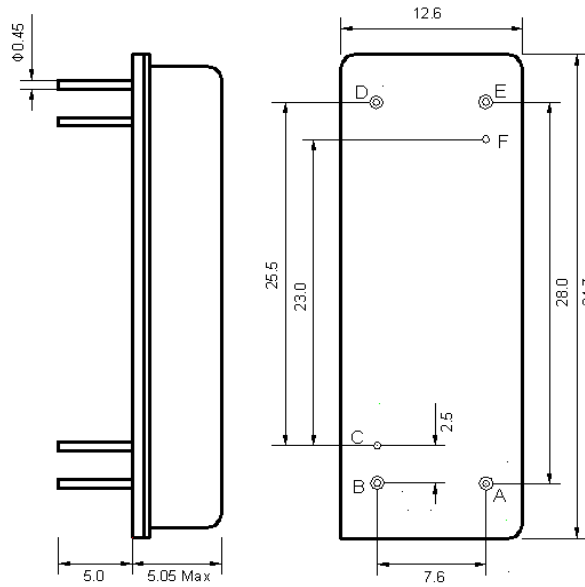

Pin Description	
B, C, E, F	Ground
A	Input
D	Output

Testing Environment

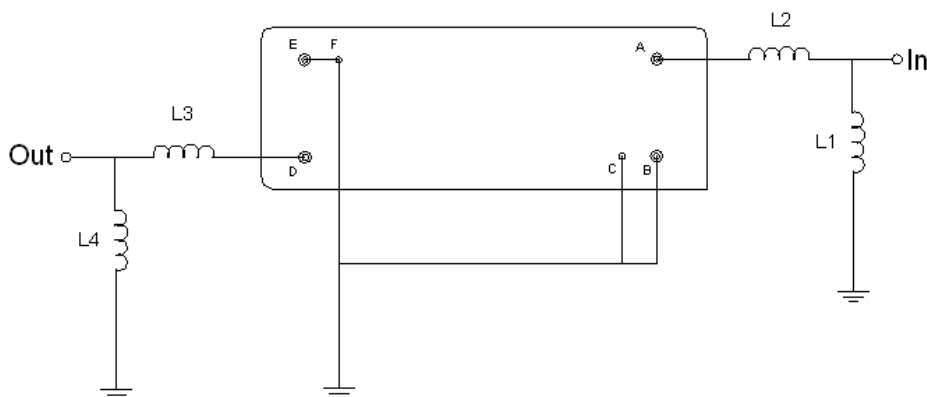

Test Fixture & Values	
Input	L1=22 nH, L2=22 nH
Output	L3=27 nH, L4=18 nH
Source/Load Impedance	50 Ω



Frequency Characteristics

Frequency Response

Bandwidth at -1.0 dB

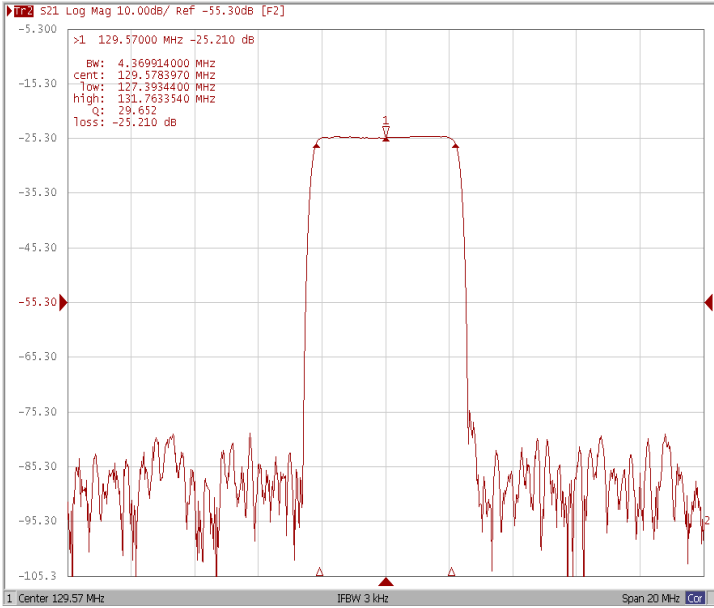

Bandwidth at -3.0 dB

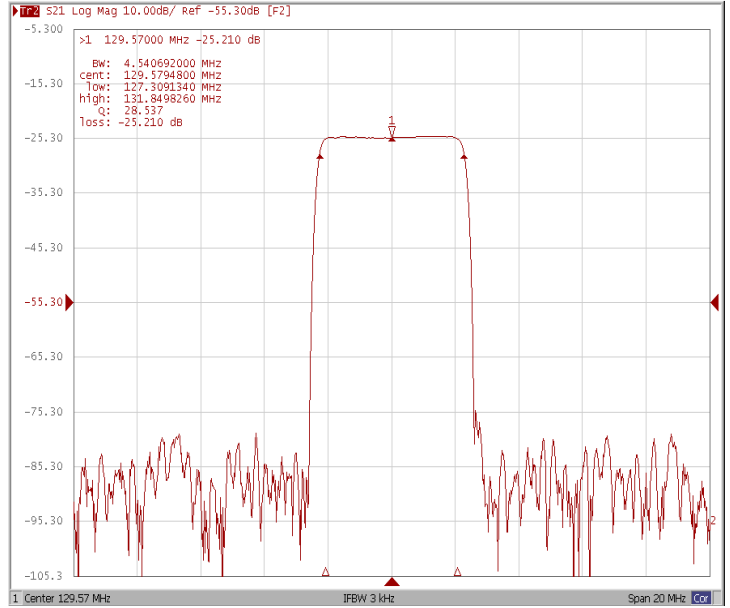

Bandwidth at -45.0 dB

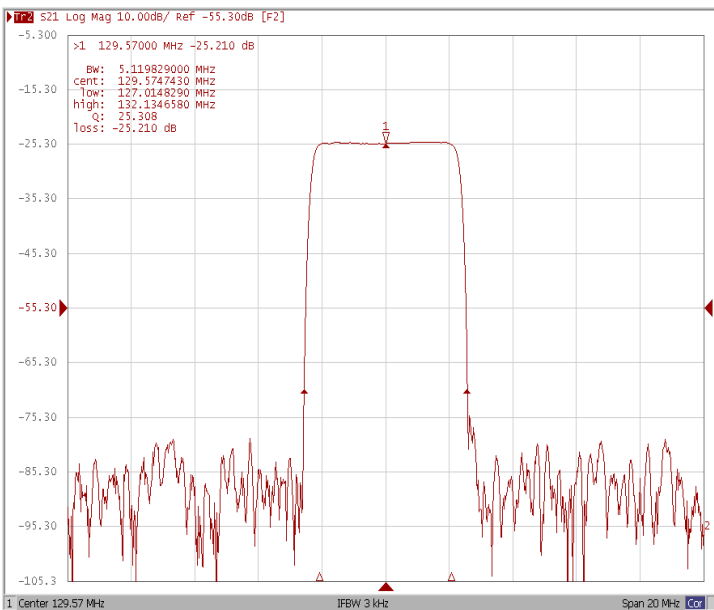

Relative Attenuation

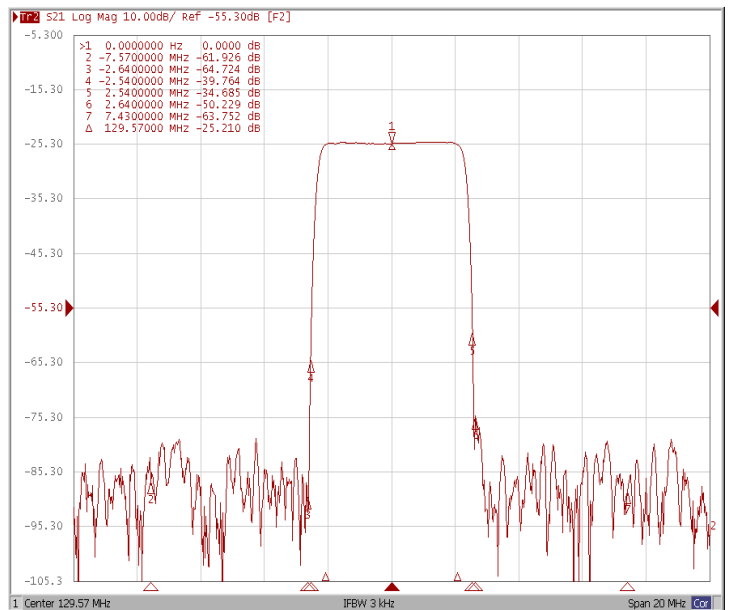



Frequency Characteristics

Frequency Response

Ripple Variation Fo±2.07MHz

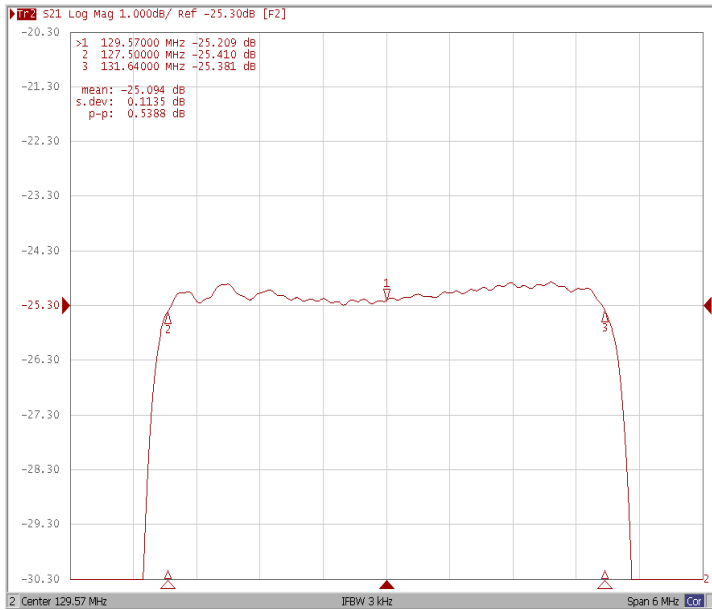

Group Delay Variation Fo±2.07MHz

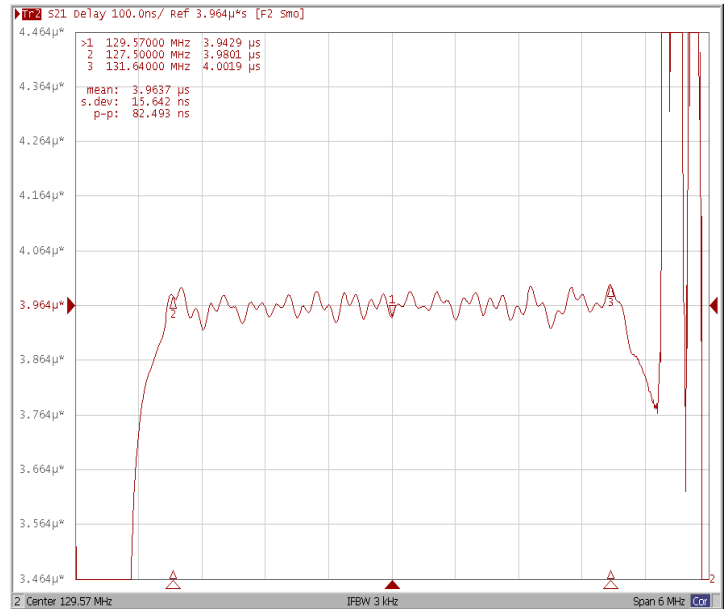

Phase Linearity Fo±2.07MHz

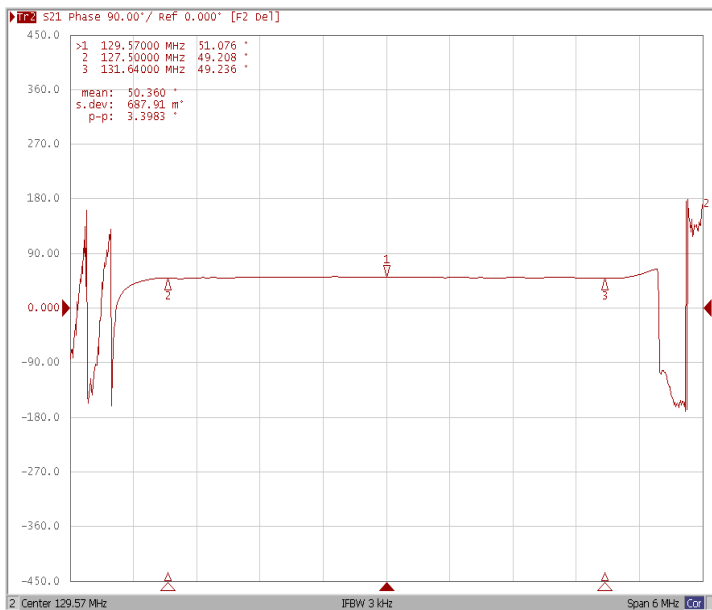

Smith Chart

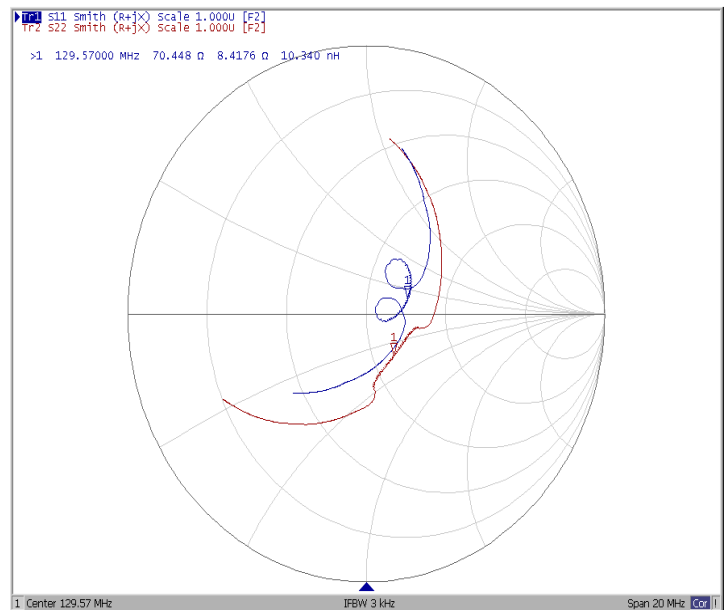



Frequency Characteristics

Frequency Response

Return Loss S11

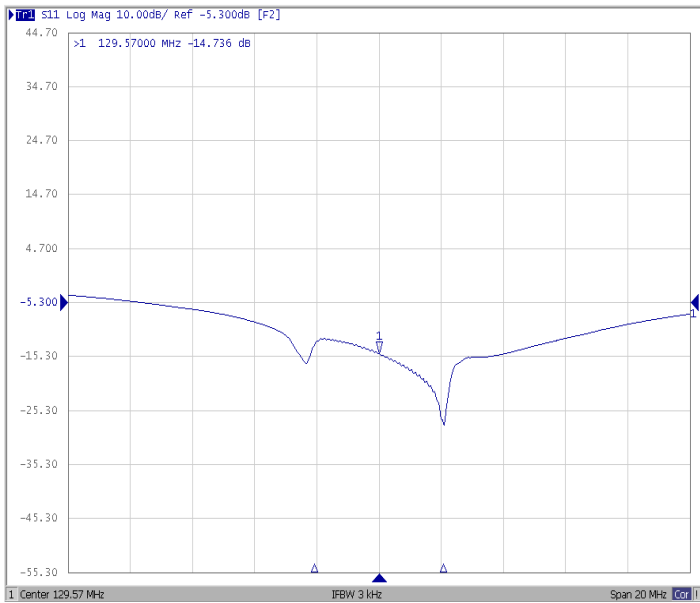

Return Loss S22

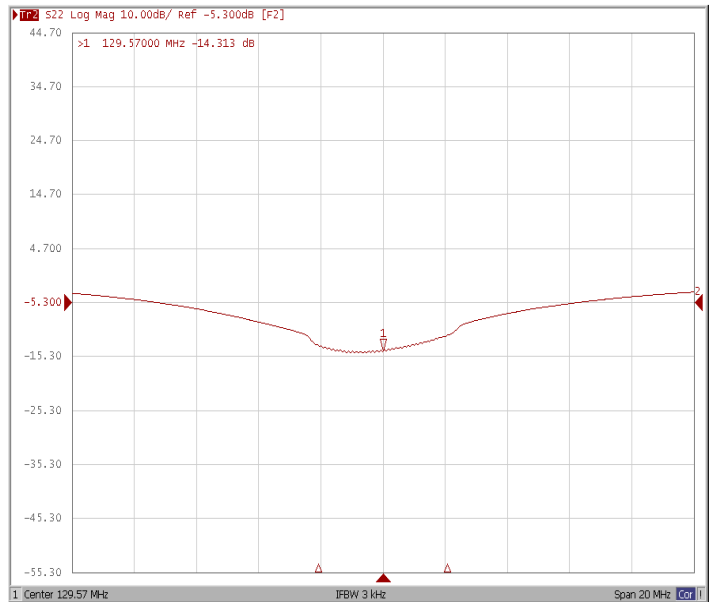

VSWR S11

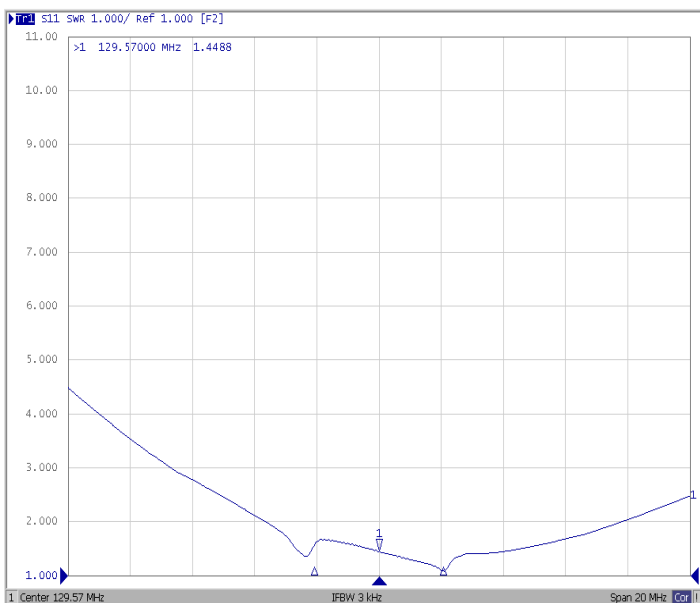

VSWR S22

